



# HERCULES 20-30-40-50

impastatrici pizza  
*pizza dough mixers*



YouTube



Industria 4.0

- Struttura in acciaio C40 a grosso spessore.
- Verniciatura antigraffio a polveri epossidiche alimentare.
- Vasca con bordo rinforzato e asta rompi pasta in acciaio AISI 304.
- Spirale forgiata.
- Coperchio vasca conforme alle normative con foro per aggiunta prodotto in lavorazione.
- Motore potente e ventilato con riduttore a vite senza fine a bagno d'olio.
- Protezione termica motore.
- Trasmissione moto interno con catena rinforzata.
- Comandi a bassa tensione resistenti IP 67.

## VERSIONE TA

- Testa sollevabile.
- Vasca asportabile.

## Opzioni:

- Ruote e timer.
- 2 velocità.
- Coperchio griglia, solo per mercati no CE.
- SRCS Scheda di controllo remoto

- *Made from large thickness C40 steel.*
- *Scratch resistant powder coating.*
- *Bowl with reinforced edge and AISI 304 S/S shaft.*
- *Forged spiral tool.*
- *Lid with opening to add ingredients during operation.*
- *High efficiency ventilated motor with oil-bath gear box.*
- *Thermal overload protection circuit breaker.*
- *Reinforced chain drive.*
- *Low voltage IP67 protection rated controls.*

## TA VERSION

- *Liftable head for tank removal and easy clearing.*
- *Removable container.*

## Optionals:

- *Wheels and timer.*
- *2 speed version.*
- *Grill cover, no CE markets only.*
- *SRCS wifi control board*



## HERCULES 50

Timer opzionale  
*Optional timer*



HERCULES 40 TA

Coperchio griglia e ruote opzionali  
*Optionals grill cover and wheels*





Testa sollevabile  
*Liftable head*

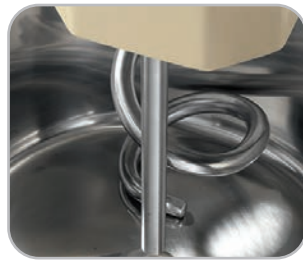

Asta rompipasta  
*Shaft*



Comandi con timer opzionale  
*Controls with optional timer*



Comandi 2V  
*2V controls*



Coperchio con foro per aggiunta prodotto  
*Lid with opening to add ingredients*

### HERCULES

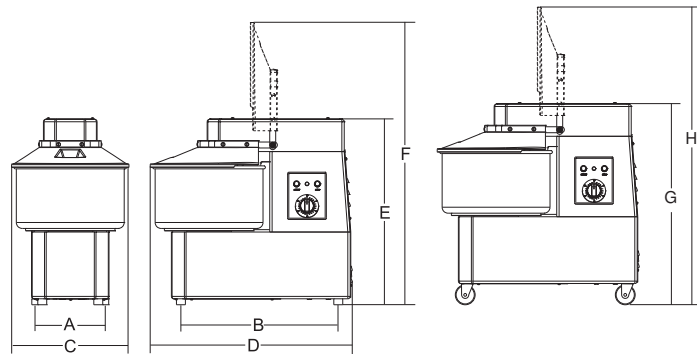

### HERCULES TA

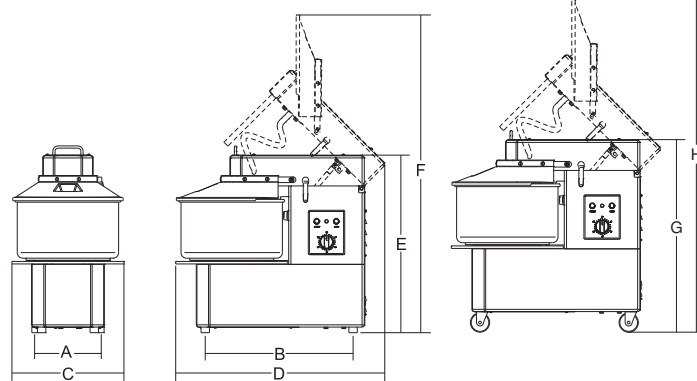

								A	B	C	D	E	F	G	H			
	watt/HP		r.p.m.	r.p.m.	lt	kg	mm	mm	mm	mm	mm	mm	mm	mm	mm	kg	mm	kg
<b>Hercules 20B</b>	750/1	1ph/3ph	10	85	21	17	∅ 360x210	230	530	390	680	625	950	705	1030	66	530x830x1020	76
<b>Hercules 20</b>	750/1	1ph/3ph	10	85	21	17	∅ 360x210	230	530	390	680	625	950	705	1030	72	530x830x1020	84
<b>Hercules 30</b>	1.100/1.5	1ph/3ph	10	85	32	25	∅ 400x260	270	590	440	740	700	1050	780	1130	118,5	530x830x1020	133,5
<b>Hercules 40</b>	1.500/2	1ph/3ph	10	85	41	35	∅ 452x260	310	660	480	825	730	1135	810	1215	123,5	630x970x1070	138,5
<b>Hercules 50</b>	1.500/2	1ph/3ph	10	85	52	44	∅ 500x270	310	680	540	880	750	1205	830	1285	149	630x970x1070	168
<b>Hercules 20 2V</b>	750-1.100/ 1-1.5	1ph/3ph	1V= 10 2V= 20	1V= 85 2V= 170	21	17	∅ 360x210	230	530	390	680	625	950	705	1030	72	530x830x1020	84
<b>Hercules 30 2V</b>	1.000-1.400/ 1.36-1.9	1ph/3ph	1V= 10 2V= 20	1V= 85 2V= 170	32	25	∅ 400x260	270	590	440	740	700	1050	780	1130	118,5	530x830x1020	133,5
<b>Hercules 40 2V</b>	1.500-2.200/ 2-3	1ph/3ph	1V= 10 2V= 20	1V= 85 2V= 170	41	35	∅ 452x260	310	660	480	825	730	1135	810	1215	123,5	630x970x1070	138,5
<b>Hercules 50 2V</b>	1.500-2.200/ 2-3	1ph/3ph	1V= 10 2V= 20	1V= 85 2V= 170	52	44	∅ 500x270	310	680	540	880	750	1205	830	1285	149	630x970x1070	168
<b>Hercules 20 TA</b>	750/1	1ph/3ph	10	85	21	17	∅ 360x210	230	530	400	751	635	1125	715	1205	88	530x830x1020	98
<b>Hercules 30 TA</b>	1.100/1.5	1ph/3ph	10	85	32	25	∅ 400x260	270	590	440	823	710	1260	790	1340	133	530x830x1020	148
<b>Hercules 40 TA</b>	1.500/2	1ph/3ph	10	85	41	35	∅ 452x260	310	660	490	910	740	1360	820	1440	138	630x970x1070	153
<b>Hercules 50 TA</b>	1.500/2	1ph/3ph	10	85	52	44	∅ 500x270	310	680	540	970	795	1415	875	1495	164	630x970x1070	183